

WEIGHT 3.952 LBS		SURFACE AREA 296.795 IN.²		PART DESCRIPTION REAR STREET STOCK MOUNT SHOCK			
BREAK EDGES .010 +/- 0.005" X 45°, FILLET RADII 0.010" +/- 0.005" TOLERANCES (UOS): .XX +/- .01", .XXX +/- .003", ANG +/- 0.5°				MATERIAL RELATIVE TO COMPONENTS			
ALL SURFACE FINISHES TO BE Ra 64 OR BETTER UNLESS OTHERWISE SPECIFIED.				DWG. NO. 310 47180			
THIS DRAWING, INFORMATION, AND TECHNICAL DATA CONTAINED WITHIN ARE THE EXCLUSIVE PROPERTY OF INTEGRA SHOCKS AND SHALL BE RETURNED UPON REQUEST. THIS DRAWING IS NOT TO BE REPRODUCED IN WHOLE OR IN PART, NOR SHALL ANY INFORMATION OR TECHNICAL DATA BE SUPPLIED, IN ANY FORM, TO ANYONE ELSE WITHOUT THE EXPRESS WRITTEN CONSENT OF INTEGRA SHOCKS.				DRAWN BY EKM		APPROVAL KWK	
				SIZE B	SCALE 2:5	SHEET 2 OF 2	REV. A

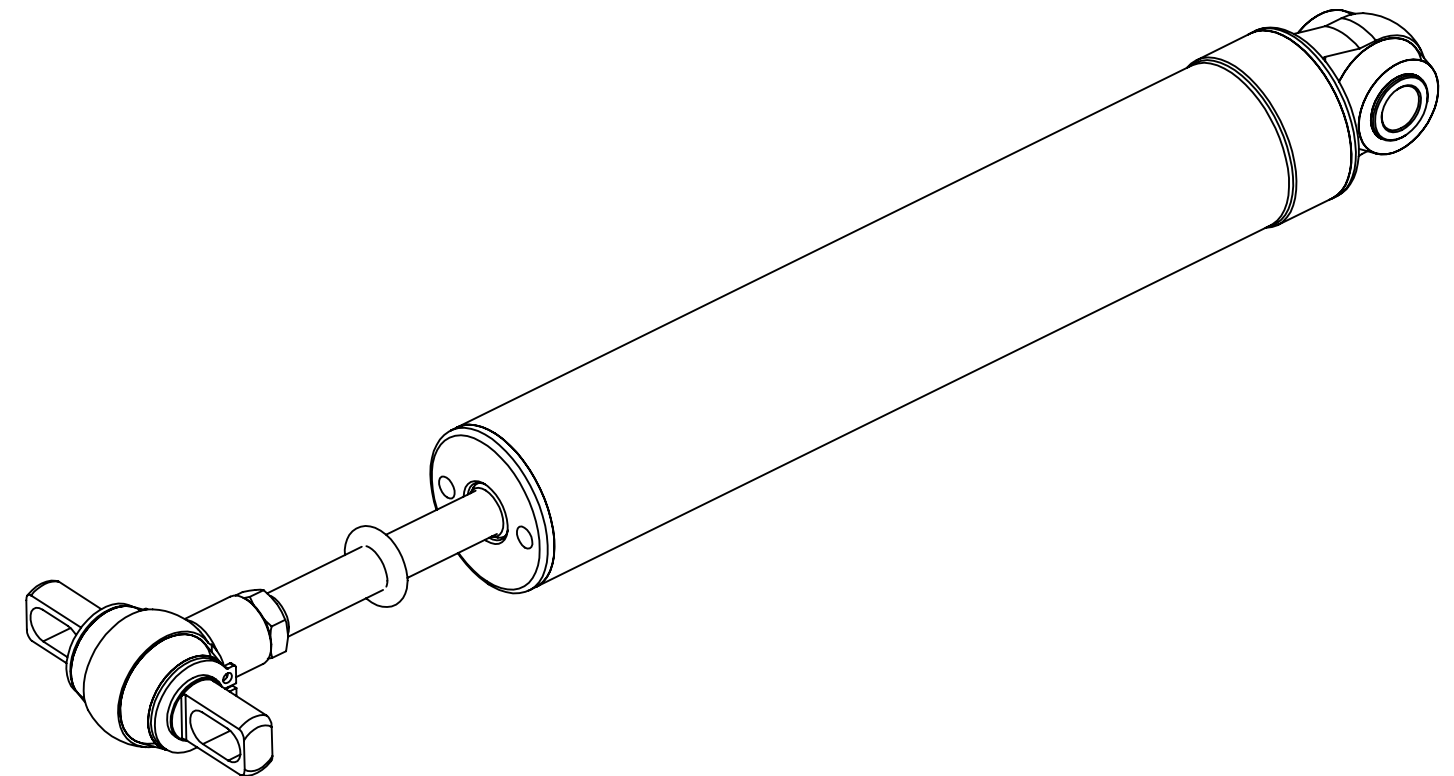

REVISIONS					
ZONE	REV.	DESCRIPTION	DATE	APPROVED	EPCN NO.
	A	ASSEMBLY CREATED	5/21/2019	KWK	



ITEM NO.	PART NUMBER	PART DESCRIPTION	QTY.
1	310 30214	PISTON BAND	1
2	310 30215	PISTON O-RING	1
3	310 30216	5/16-24 YZ ROD NUT	1
4	310 30217	5/16 FLAT WASHER	1
5	310 30218	TRAVEL INDICATOR	1
6	310 30226	ROD GUIDE - STEEL SHOCK ASSEMBLY	1
7		PISTON OF CHOICE - STREET STOCK	1
8	310 30396	TRAVEL LIMITER - DISC	1
9	310 30338	HEX JAM NUT	1
10	310 47002-R	STREET STOCK RODEND W/ 47010	1
11	310 47026	STANDARD PISTON ROD - X"	1
12	310 47056-10	STREET STOCK REAR TUBE ASSEMBLY	1
13		COMPRESSION VALVE DISC STACK	1
14		REBOUND VALVE DISC STACK	1
15	310 TW594020	TORQUE WASHER	4

WEIGHT	SURFACE AREA	PART DESCRIPTION			
3.952 LBS	296.795 IN. ²	REAR STREET STOCK MOUNT SHOCK			
BREAK EDGES .010 +/- 0.005" X 45°, FILLET RADII 0.010" +/- 0.005" TOLERANCES (UOS): .XX +/- .01", .XXX +/- .003", ANG +/- 0.5°		MATERIAL			
ALL SURFACE FINISHES TO BE Ra 64 OR BETTER UNLESS OTHERWISE SPECIFIED.		RELATIVE TO COMPONENTS			
THIS DRAWING, INFORMATION, AND TECHNICAL DATA CONTAINED WITHIN ARE THE EXCLUSIVE PROPERTY OF INTEGRA SHOCKS AND SHALL BE RETURNED UPON REQUEST. THIS DRAWING IS NOT TO BE REPRODUCED IN WHOLE OR IN PART, NOR SHALL ANY INFORMATION OR TECHNICAL DATA BE SUPPLIED, IN ANY FORM, TO ANYONE ELSE WITHOUT THE EXPRESS WRITTEN CONSENT OF INTEGRA SHOCKS.		DWG. NO.	DRAWN BY	APPROVAL	
		310 47180	EKM	KWK	
SIZE	SCALE	SHEET	REV.		
B	1:2	1 OF 2	A		

5

4

3

2

1

5

4

3

2

1

E

E

D

D

C

C

B

B

A

A