

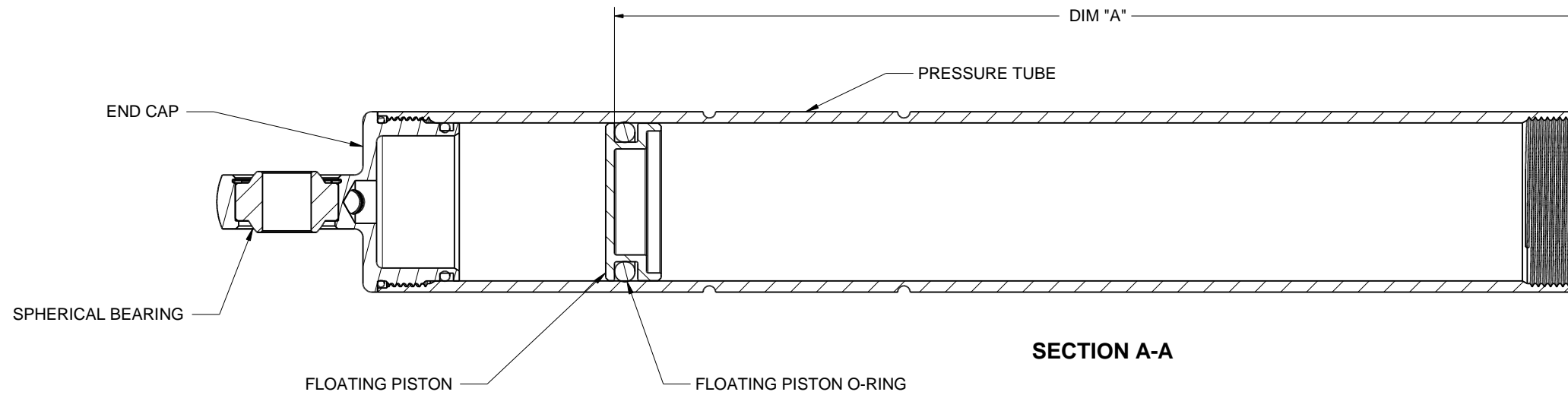

REVISIONS			
REV	DESCRIPTION	DATE	APPROVED

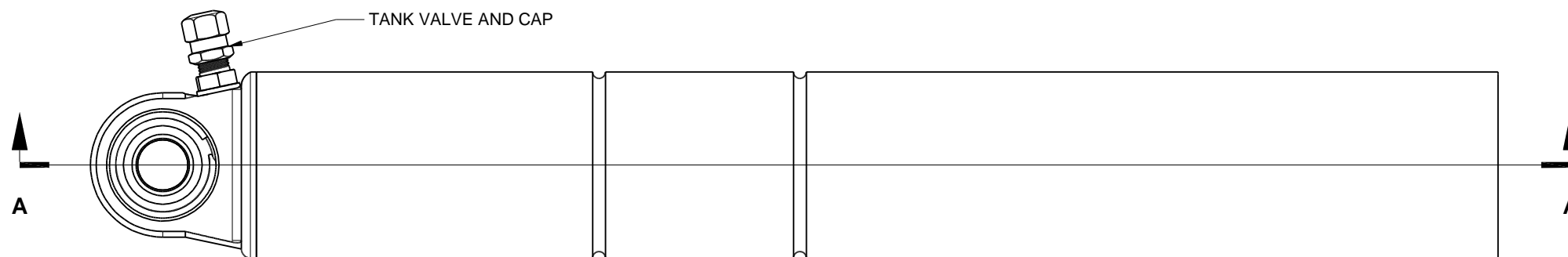

PRESSURE TUBE	DIM "A"
5"	6-1/4"
6"	7-1/4"
7"	8-1/4"
8"	9-1/4"
9"	10-1/4"



NOTES:

THIS DRAWING, INFORMATION, AND TECHNICAL DATA CONTAINED WITHIN ARE THE EXCLUSIVE PROPERTY OF INTEGRA RACING SHOCKS AND SHALL BE RETURNED UPON REQUEST. THIS DRAWING IS NOT TO BE REPRODUCED IN WHOLE OR IN PART, NOR SHALL ANY INFORMATION OR TECHNICAL DATA BE SUPPLIED, IN ANY FORM, TO ANYONE ELSE WITHOUT THE EXPRESS WRITTEN CONSENT OF INTEGRA RACING SHOCKS

BREAK EDGES .010 +/- 0.005" X 45°, FILLET RADII 0.010" +/- 0.005"
 TOLERANCES (UOS): .XX +/- .01", .XXX +/- .003", ANG +/- 0.5°
 ALL SURFACE FINISHES TO BE Ra 64 OR BETTER UNLESS OTHERWISE SPECIFIED.

PART DESCRIPTION			
AVENGER FLOATING PISTON SET HEIGHT			
MATERIAL			
MATERIAL			
DRAWN BY		APPROVAL	
KWK			
SIZE	FSCM NO.	DWG NO.	REV
B		IES1008-2	A
SCALE		SHEET 1 OF 1	