

WEIGHT 4.501 LBS		SURFACE AREA 424.798 IN. ²		PART DESCRIPTION STEEL BASE VALVE SHOCK WITH IDA TUBE		
BREAK EDGES .010 +/- 0.005" X 45°, FILLET RADII 0.010" +/- 0.005" TOLERANCES (UOS): .XX +/- .01", .XXX +/- .003", ANG +/- 0.5°				MATERIAL		
ALL SURFACE FINISHES TO BE Ra 64 OR BETTER UNLESS OTHERWISE SPECIFIED.				RELATIVE TO COMPONENTS		
THIS DRAWING, INFORMATION, AND TECHNICAL DATA CONTAINED WITHIN ARE THE EXCLUSIVE PROPERTY OF INTEGRA SHOCKS AND SHALL BE RETURNED UPON REQUEST. THIS DRAWING IS NOT TO BE REPRODUCED IN WHOLE OR IN PART, NOR SHALL ANY INFORMATION OR TECHNICAL DATA BE SUPPLIED, IN ANY FORM, TO ANYONE ELSE WITHOUT THE EXPRESS WRITTEN CONSENT OF INTEGRA SHOCKS.		DWG. NO. 310 402XXS-BVIDA		DRAWN BY EKM		APPROVAL KWK
SIZE B	SCALE 2:5		SHEET 2 OF 2		REV. A	

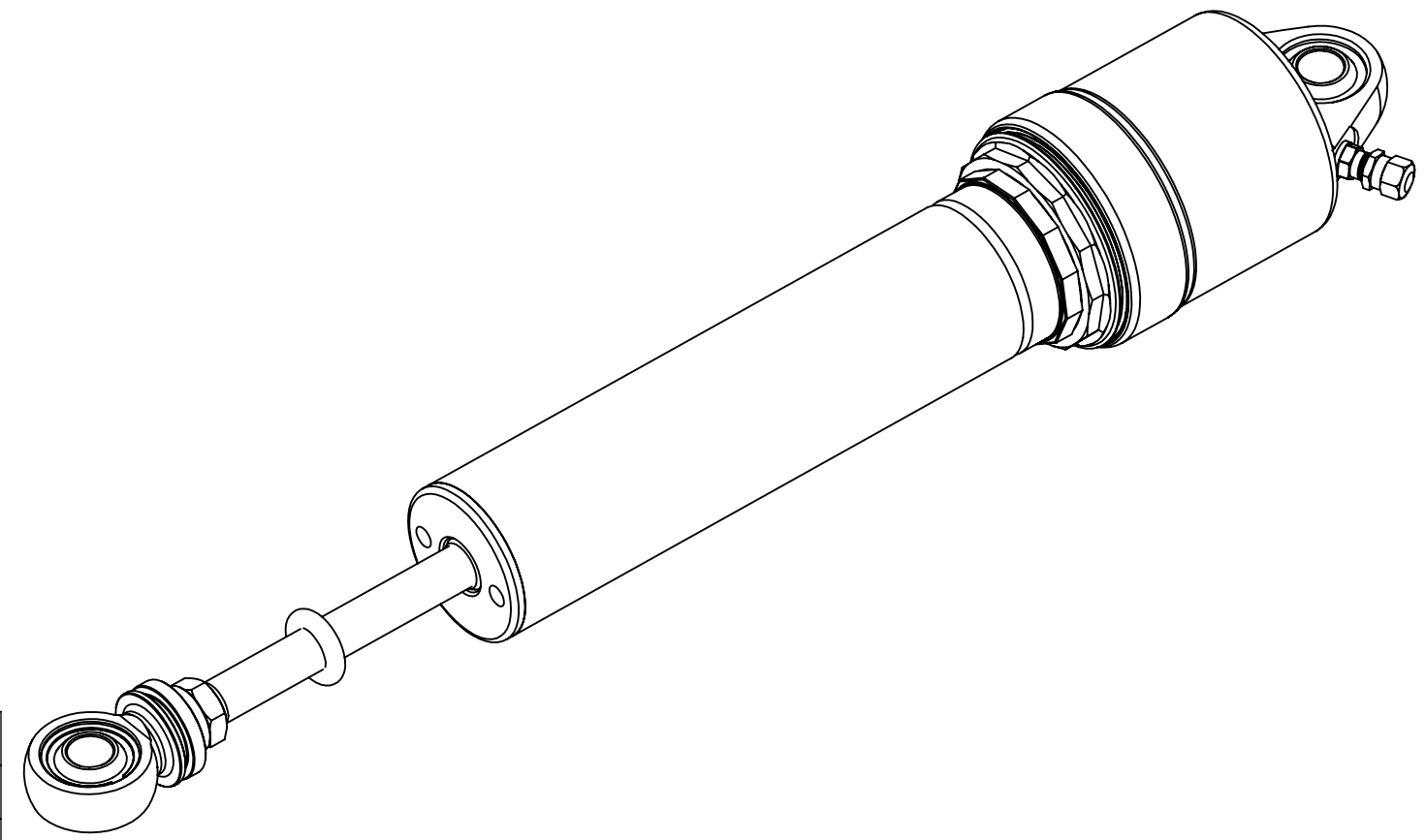

REVISIONS					
ZONE	REV.	DESCRIPTION	DATE	APPROVED	EPCN NO.
	A	MODEL CREATED	6/3/2019	KWK	



ITEM NO.	PART NUMBER	PART DESCRIPTION	QTY.
1	310 30214	PISTON BAND	1
2	310 30215	PISTON O-RING	1
3	310 30234	M10 WASHER, POST	1
4	310 3031X-10S	STANDARD STEEL SHAFT ASSEMBLY	1
5		PISTON OF CHOICE	1
6	310 30396	TRAVEL LIMITER - DISC	2
7	310 60040-XX	BASE ASSEMBLY, IDA	1
8	310 60013	3/8 - 24 JAM NUT GR8 YZ	1
9		COMPRESSION VALVE DISC STACK	1
10		REBOUND VALVE DISC STACK	1
11	310 TW594020	TORQUE WASHER	6

WEIGHT	SURFACE AREA	PART DESCRIPTION			
4.501 LBS	424.798 IN. ²	STEEL BASE VALVE SHOCK WITH IDA TUBE			
BREAK EDGES .010 +/- 0.005" X 45°, FILLET RADII 0.010" +/- 0.005" TOLERANCES (UOS): .XX +/- .01", .XXX +/- .003", ANG +/- 0.5°		MATERIAL			
ALL SURFACE FINISHES TO BE Ra 64 OR BETTER UNLESS OTHERWISE SPECIFIED.		RELATIVE TO COMPONENTS			
THIS DRAWING, INFORMATION, AND TECHNICAL DATA CONTAINED WITHIN ARE THE EXCLUSIVE PROPERTY OF INTEGRA SHOCKS AND SHALL BE RETURNED UPON REQUEST. THIS DRAWING IS NOT TO BE REPRODUCED IN WHOLE OR IN PART, NOR SHALL ANY INFORMATION OR TECHNICAL DATA BE SUPPLIED, IN ANY FORM, TO ANYONE ELSE WITHOUT THE EXPRESS WRITTEN CONSENT OF INTEGRA SHOCKS.		DWG. NO.	DRAWN BY	APPROVAL	
		310 402XXS-BVIDA	EKM	KWK	
SIZE	SCALE	SHEET	REV.		
B	1:2	1 OF 2	A		

5

4

3

2

1

5

4

3

2

1

E

E

D

D

C

C

B

B

A

A